



Circuit Breaker

ES-2000: EVERYTHING YOU NEED IN ONE PLACE With the Hackney ES-2000 service body's enormous capacity and the "everything-at-your-fingertips" shelving systems, you'll save time and break the circuit of trips to the supply shop. Take everything you need to the job every time with the only complete system designed and built with the electrical contractor in mind. Sturdy trays hold parts and supplies. Expensive ladders lock away safe and sure, plus there's plenty of room for power tools, drop cords and more. The ES-2000 makes your electrical business a more efficient, more profitable business. **Call today: 1-800-763-0700**

FAST FACTS

- Stand-up headroom (75")
- Three interior dome lights
- Full width doors swing out – continuous stainless hinges
- Spring rod door retainers to hold doors 90 degrees out
- Heavy-duty deadbolt lock assembly with deluxe handle and push cylinder
- Racks hold four stepladders plus a 24-foot extension ladder
- Adjustable shelves on vertical tracks for parts and equipment
- Subdivided parts trays for inventory
- Wire spool holders, floor level roll wire racks, fluorescent tube holders, conduit and ground rod storage and floor mat storage
- Vertical tool rack for tools with long handles
- Technician's toolbox storage area
- Perforated tool hanging panel

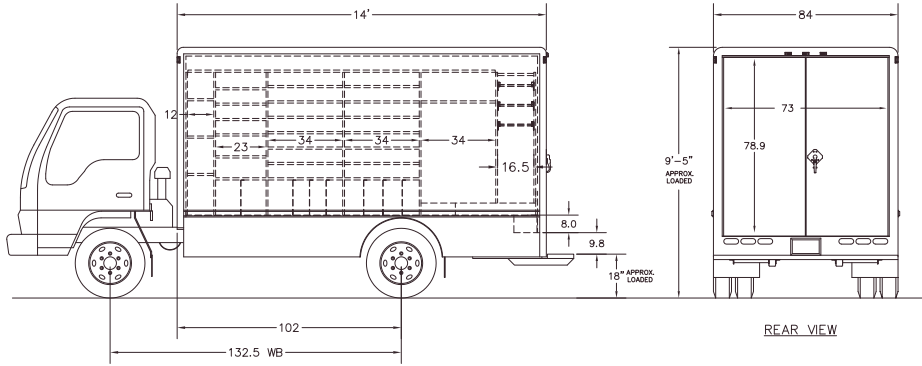

ES-2000 Rear view

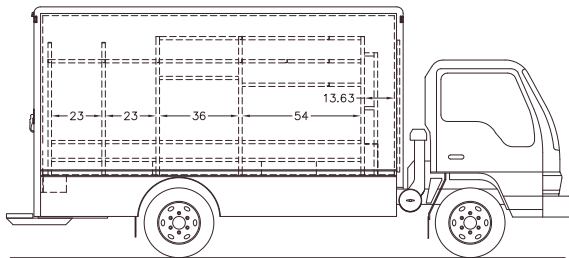

ES-2000 Driver's side shelving



ES-2000 Curbside shelving

Dimensions

- Width 84"
- Length 14'
- Headroom 75"
- Height from ground approximately 9'4" diesel / 9'6" gas (loaded)
- Tilt cab gas or diesel (132" WB 111"CA)
- GVWR 12,000 lbs. to 14,500 lbs.

Standard Equipment

- Roof**
 - Double wall sheet aluminum w/insulation
- Floor**
 - Aluminum interlocking panels with safety tread
 - Drop floor in rear for walk-in access
- Interior**
 - Double wall front, rear doors, and rear side panels
- Rear**
 - Aluminum step type bumper with open safety grating - approximately 18" above ground
 - Aluminum diamond plate scuff panel above bumper
 - Mud flaps
- Rear Door**
 - Full width double swing-out - continuous stainless steel hinges
 - 78.9"H x 73"W - double wall aluminum
 - HD deadbolt lock assembly with deluxe handle and push cylinder
 - Spring rod door retainers to hold doors 90 degrees out
- Interior Shelves**
 - All aluminum infinitely adjustable/removable on vertical tracks

Interior Shelves, continued

- CS -25" depth; DS 18" depth; aisle width 37"
- Curbside: Ladder storage for 24" extension plus 12', 8' 6", and 4' step ladders
- Drivers Side: Wire storage-spool rack for 8-12 rolls, vertical dividers for 10 rolls wire/cable
- Bin Storage - Adjustable shelves for more than 50 plastic parts trays
- Miscellaneous Self Storage - 20 lineal feet, tool panel, mat rack, space for tool cabinet, tools, drop cords, safety equipment, supplies, quick access items

Interior Lights

- 3 clear overhead dome lights with switch at rear and cab master

Paint

- One color- white to match cab

Chassis Alteration and Body Mounting

- Drop frame behind rear axle for lower rear entrance

Optional Equipment

- Fluorescent Dome Lights** (in lieu of three round)
 - Three double tube lights - 18"L 30 watt
- Translucent Roof**
- Two Salem Roof Vents**
 - 4" x 9" two-way open and close
- Back-up Alarm** (if not included with chassis)
- Door Ajar Alarm / Pilot Light**
- D.O.T. Safety Kit**
 - Includes 2.5# FE, triangle warning, flashlight
- 8" Eyeball Rearview Mirror**
 - Located upper rear corner drivers side
- Rear View Video Camera** (5" B&W monitor)
- High Security Exterior Hockey Puck Style Door Lock** (in addition to standard lock)

Plastic Storage Trays for ES Interior Layout

- Set of 66 trays including dividers, label holders
- 8 - 3.5"H x 11"W x 16"L with 8 large and 36 small dividers
- 47 - 5"H x 11"W x 16"L with 72 large and 120 small dividers
- 4 - 8"H x 11"W x 16"L with 4 large and 4 small dividers
- 7 - 8"H x 17"W x 22"L with 3 large and 12 small dividers

Class III Receiver Hitch (with wiring)

- Seven-prong plug and draw bar. Ball not included.

Pull Out Ramp Under Floor

- 9'6" L x 24.5" W (inside) with access door in stepwell

Pipe Compartment Under Floor

- 5" H x 27"W x 124"L (in lieu of ramp)

Skirt Storage Compartment

- Inside dimensions 11.75"H x 15.25"D x 29.75"W (8" x 26" door opening)

Box of 24 Assorted Brackets for Hanging Tools on Rear Doors

- Hang tools such as wrenches, brooms, dust pans, shovels, hammers, tube benders, cutters, etc.

Stainless Steel Wheel Covers for Cab Over Chassis

- 16" wheels
- 19.5" wheels

Paint Body or Cab Solid Color Other Than White Custom Paint Design Body or Cab Decals and Graphics Application

- Price upon request